

RELEASE

DATE:

COMPANY:

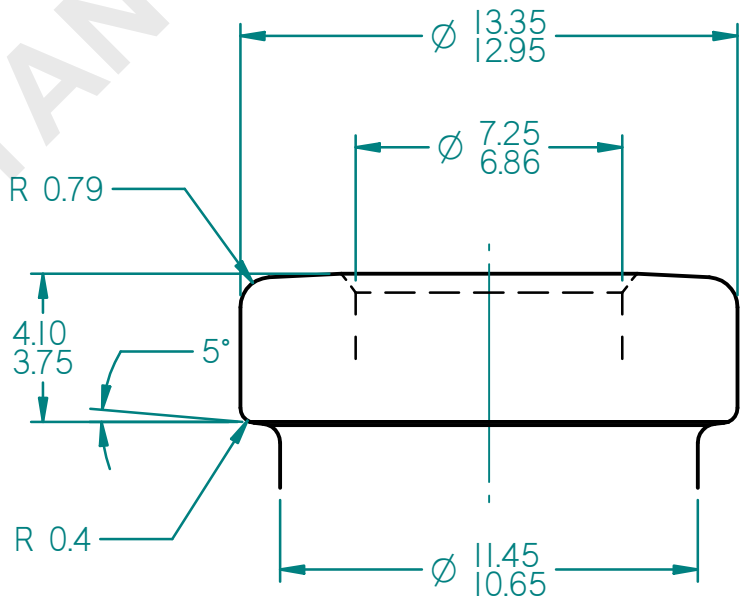
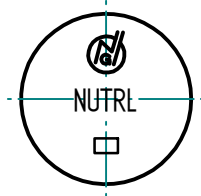
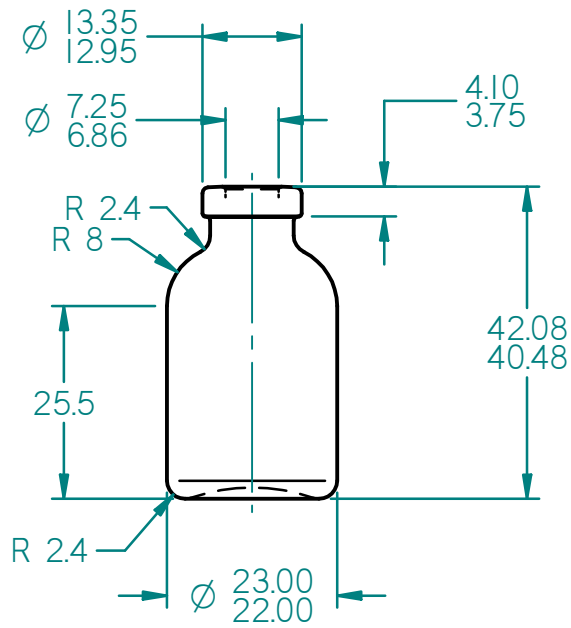

FINISH : 13 mm STD.

Protective note ISO 16016 observed

GENERAL TOLERANCES DIN 6129-1 (DIMENSIONS WITHOUT TOLERANCES ARE FOR REFERENCE ONLY)				FINISH: 13 mm STD.		O'FLOW CAPACITY: 7.50 - 8.50 ml		ARTICLE NO.:			
				FINISH DWG: NA		WEIGHT: 13 g Approx		5151080100			
				FINISH MOLD NO: 901		TYPE OF GLASS: I COLOUR: FLINT					
				DATE		NAME		TITLE: <h1 style="text-align: center;">5 ml METRO</h1>			
				DRAWN 20/11/2013		Paresh					
				CHECKED 20/11/2013		H.B.P.					
				SCALE 1 : 1, 5 : 1							
				GERRESHEIMER NEUTRAL GLASS & ALLIED INDS. PVT. LTD. MUMBAI / KOSAMBA		MOLD NO.: 003		DRAWING NO.: B 1080		REVISION 0	
								SHEET 1 OF 1		FORMAT A4	
REV. CHANGE DATE NAME				FILE: 5 ml METRO.dft							